

COMPONENT FACT SHEET

H-20 Series

Helm Unit

(H-21, H-22, H-23, H-25, H-26
H-21-01, H-25-01)

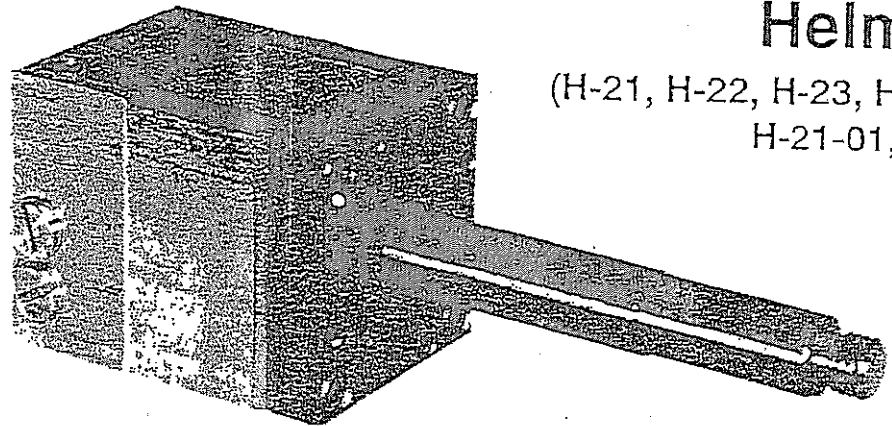
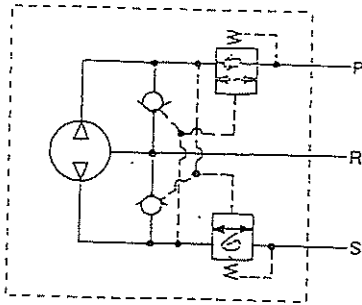

Description

The Hydraulic H-20 Series Hydraulic Helm Unit is a bi-directional, fixed displacement, axial piston pump, coupled to pilot-check and make-up check valving.

The patented pump section utilizes seven pistons, each stroked nine times with one shaft revolution, pushing fluid thru a porting block into the valve section.

The valve section includes holding valves to prevent feedback and to isolate the unit, and compensation valves to allow the use of unbalanced cylinders.

Clockwise rotation of the shaft discharges fluid thru the "S" port; counterclockwise rotation effects "P" port discharge. The "R" port is for the reservoir connection. Port size is 1/4" NPTF.

Service pressure is 1000 psi maximum with proof pressure established at 2000 psi. Maximum speed is 120 rpm.

seal backups and piston glyd rings. Other components are of friction and wear resistance materials to reduce operating torque and prolong life.

Performance

Volumetric efficiency: 90% at 1000 psi and 12 rpm.

Running torque vs. pressure:

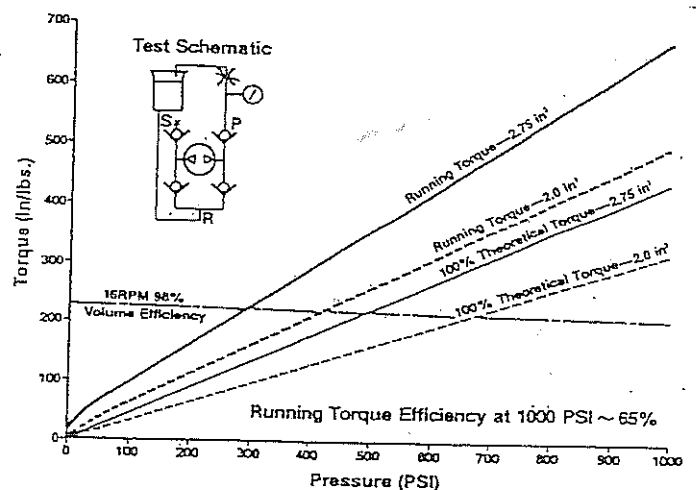

Construction

Exterior is corrosion resistant aluminum and stainless steel. Internal components — ferrous metal porting block and cylinder barrel with ground mating surfaces, hardened and ground steel pistons, drive keys, needle thrust bearings, Buna "N" seals, TFE

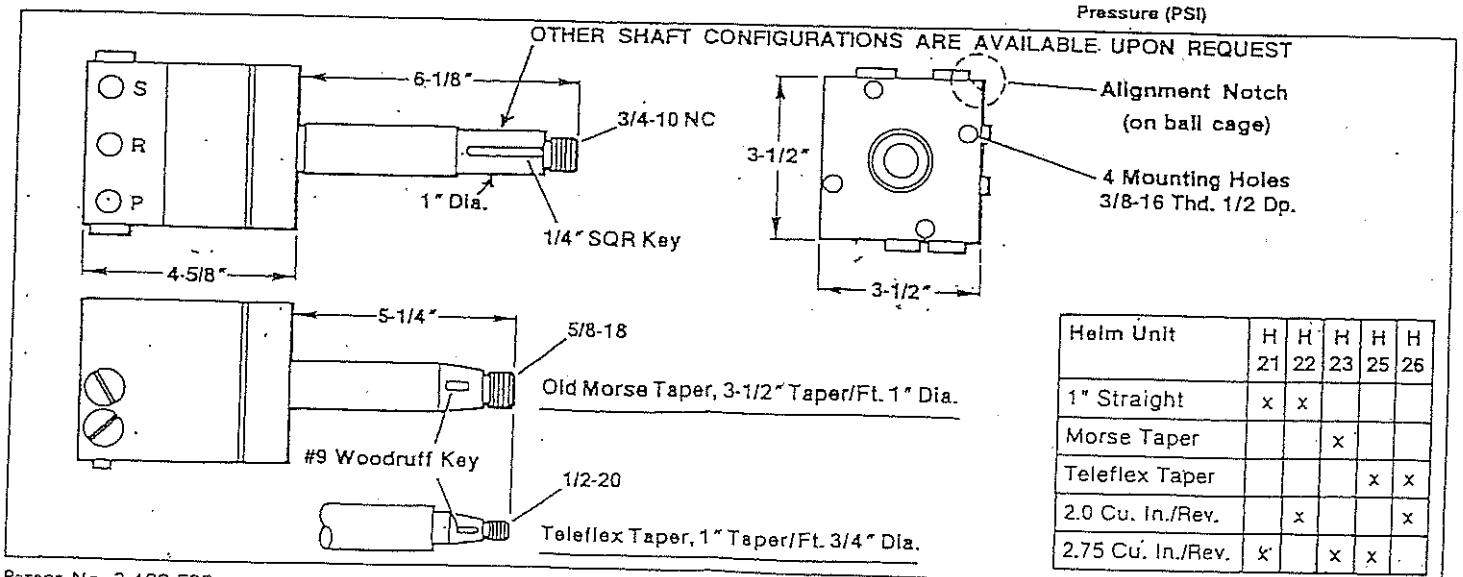

ILLUSTRATED PARTS BREAKDOWN

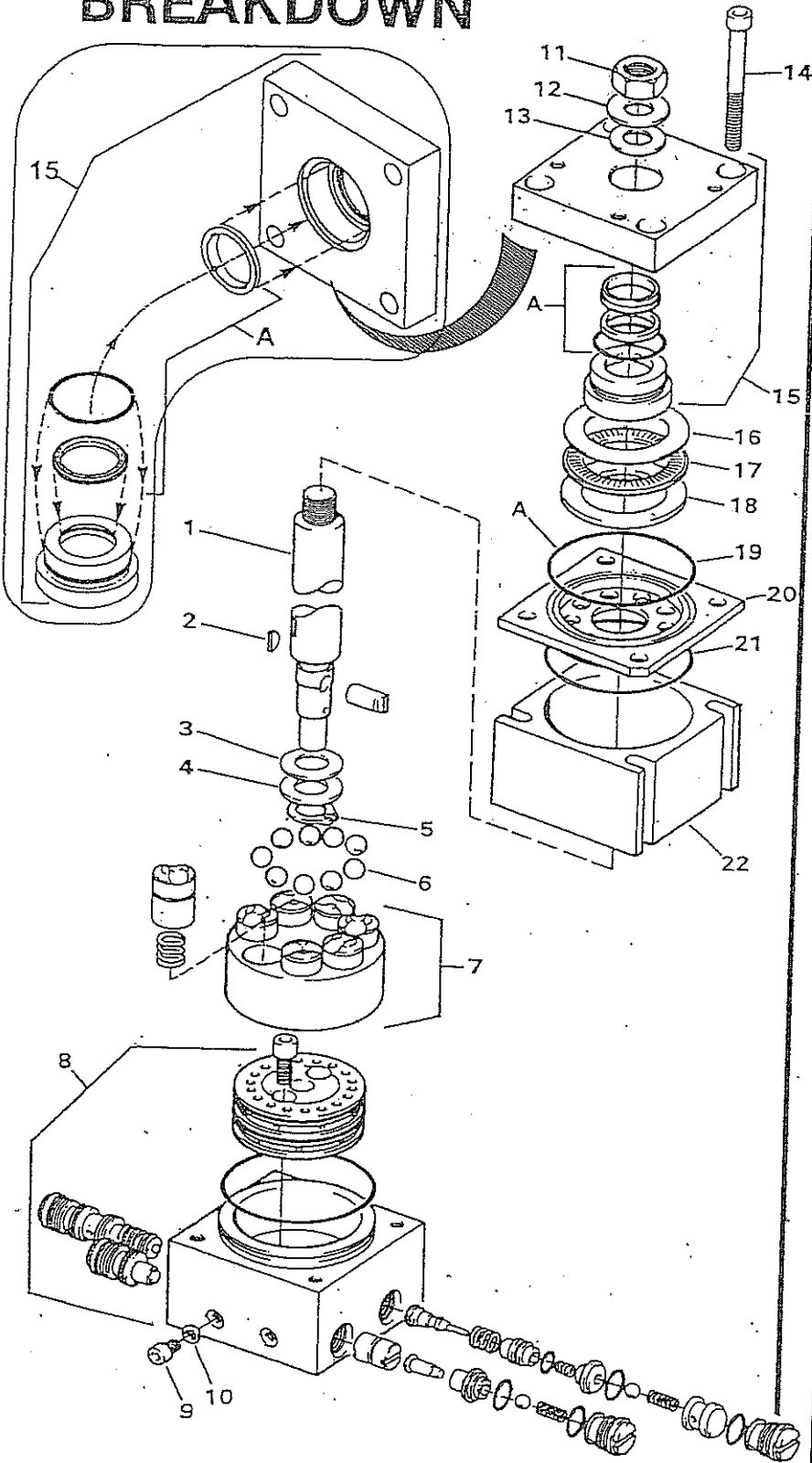

NOTE

These helm Units are manufactured under strict controls and testing procedures. Disassembly of Item No. 8 WILL VOID any existing Warranty.

It is recommended the unit be returned to Hynautic, or an authorized Hynautic repair facility for repair.

Parts Description

Item	Description	Helm Models	Part No.	Qty.
1.	Shaft	H-21, H-22	400057	1
		H-21-01	400267	1
		H-23	400117	1
		H-25, H-26	400167	1
		H-25-01	400447	1
2.	Key	H-21, H-21-01, H-22	650047	1
		H-23, H-25, H-25-01	650027	1
		H-26	650027	1
		All	740078	1
3.	Washer	All	190012	1
4.	Bearing Race	All	300046	1
5.	Retaining Ring	All	234056	9
6.	Ball	H-21, H-21-01, H-22	510080	1
		H-23, H-25, H-25-01	510080	1
		H-22, H-26	510070	1
7.	Cyl. Barrel Asby.	All	900220	1
		All	240317	2
8.	Valve Body Asby.†	All	390028	2
9.	Screw	All	340041	1
10.	Gasket	H-21, H-22, H-21-01	270071	1
		H-23	270037	1
11.	Nut	H-25, H-25-01, H-26	740011	1
		H-21, H-22	740037	1
		All	240367	4
12.	Washer	All	900300	1
13.	Washer	All	190004	1
14.	Soc. Hd. Cap Screw	All	190001	1
15.	Body Asby.-Front Cover	All	190003	1
16.	Bearing Race - thin	All	211040	1
17.	Bearing Race - thrust	All	620018	1
18.	Bearing Race - thick	All	211039	2
19.	O-Ring	All	900264	1
20.	Ball Cage	All	HS-02	
21.	O-Ring	All		
22.	Body Spacer	All		
A	Seal Kit (w spare O-Rings)	All		

†Note: The valve assembly is tested at Hynautic. Replacement of individual valve parts may produce valve leakage or failure.

CAUTION

If you disassemble the entire unit, the ball cage (No. 20) must be properly aligned with the body spacer (No. 22) and valve body assembly (No. 8). Failure to do so will result in poor pump performance. To insure proper timing: Align the notched corner of the ball cage as illustrated with the corners of the body spacer (No. 22) and valve assembly (No. 8), using as a reference the two protruding bleed screws (No. 9).



INSTALLATION INSTRUCTIONS: MOUNTING SERIES 20 AND SERIES 40 HELM UNITS

1. Helm unit dimensions and layouts are given on the back of this sheet.
2. The helm units may be mounted with the tubing ports up, down or in any position. The shaft may be at an angle if so desired. Verify after mounting that the helm unit's shaft does not bind on the panel.
3. A template is provided, this may be used for locating the shaft and mounting holes. If this template is used, the direction of the tubing ports will correspond to the horizontal and vertical lines drawn on the template.
4. For the helm unit's shaft a 1-1/4" diameter hole provides the proper clearance.

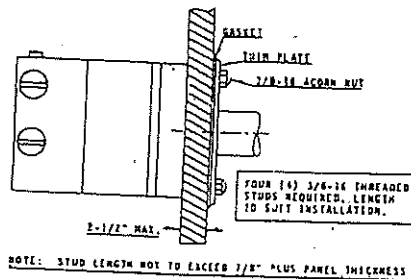

5. Extreme care must be taken to use the correct length 3/8-16 NF studs. These are provided by the boat builder, or owner, and should not exceed the thickness of the console by more than 7/8 of an inch.
6. The steering ports are marked 'S' and 'P'. Rotating the steering wheel in a clockwise direction will pressurize 'S', rotating it in the counterclockwise direction will pressurize 'P'.

INSTALLATION INSTRUCTION: TUBING

1. COPPER TUBING - .032" wall thickness. Copper tubing can be used on high pressure applications. P & S lines require 3/8" or 1/2" compression or flare fittings. R lines require 1/4" compression or flare fittings.
2. HOSE - High pressure hose may be used throughout your system. Use either Hynautic supplied hose or the equivalent of Aeroquip 2651 (SAE 100R with 1000 psi working pressure). P & S lines require 3/8" or 1/2" lines, R lines require 1/4".

INSTALLATION INSTRUCTION: FLUIDS

1. Use MIL-O-5606 Aircraft Hydraulic Fluid, Texaco #15, Shell Tellus 15 (ISO-Tellus 10) or Chevron EP-Machine Oil 10. LIGHT VISCOSITY OILS ARE RECOMMENDED, HEAVIER OILS WILL CAUSE SYSTEM STIFFNESS.

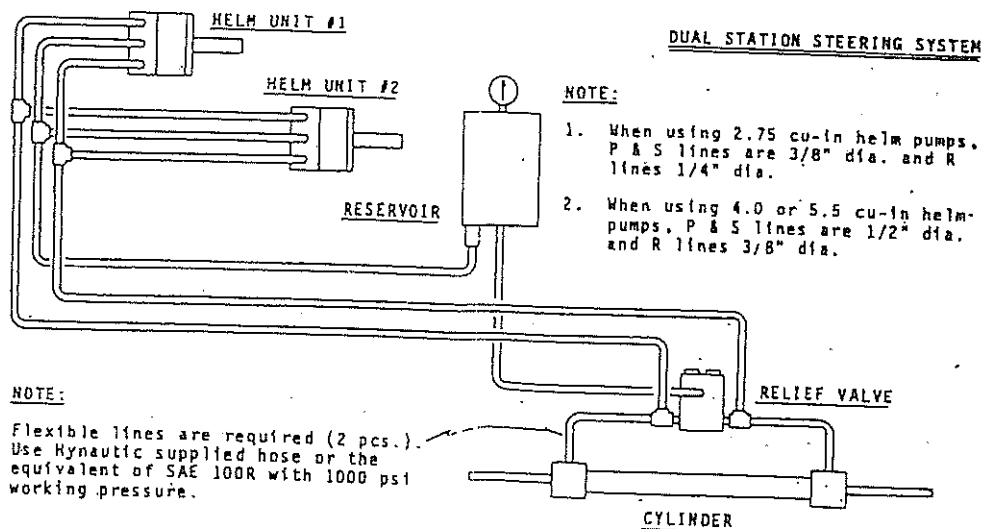

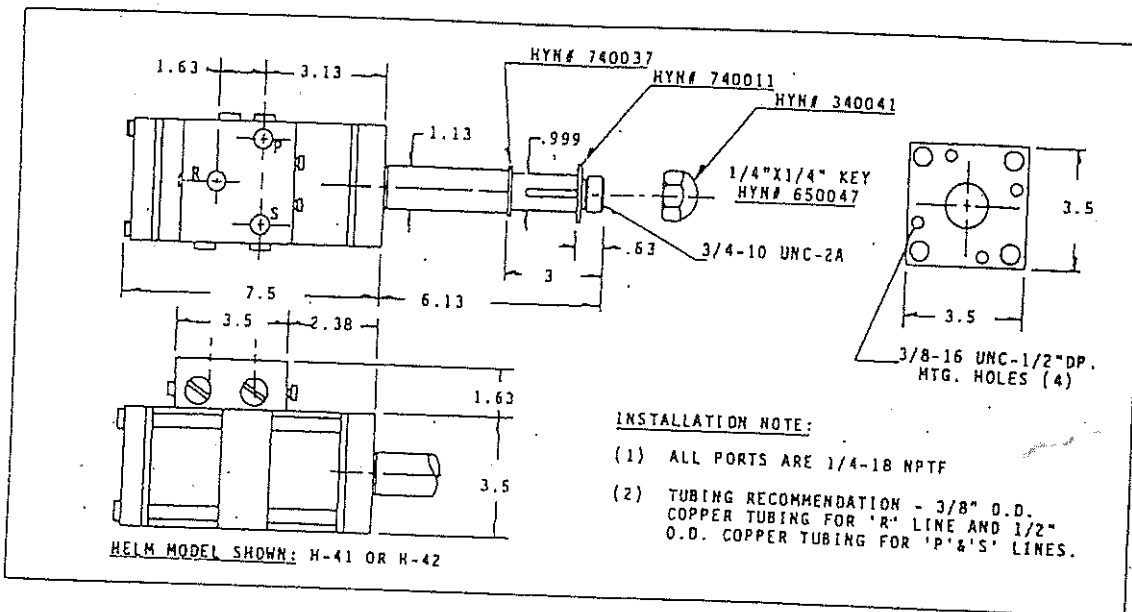
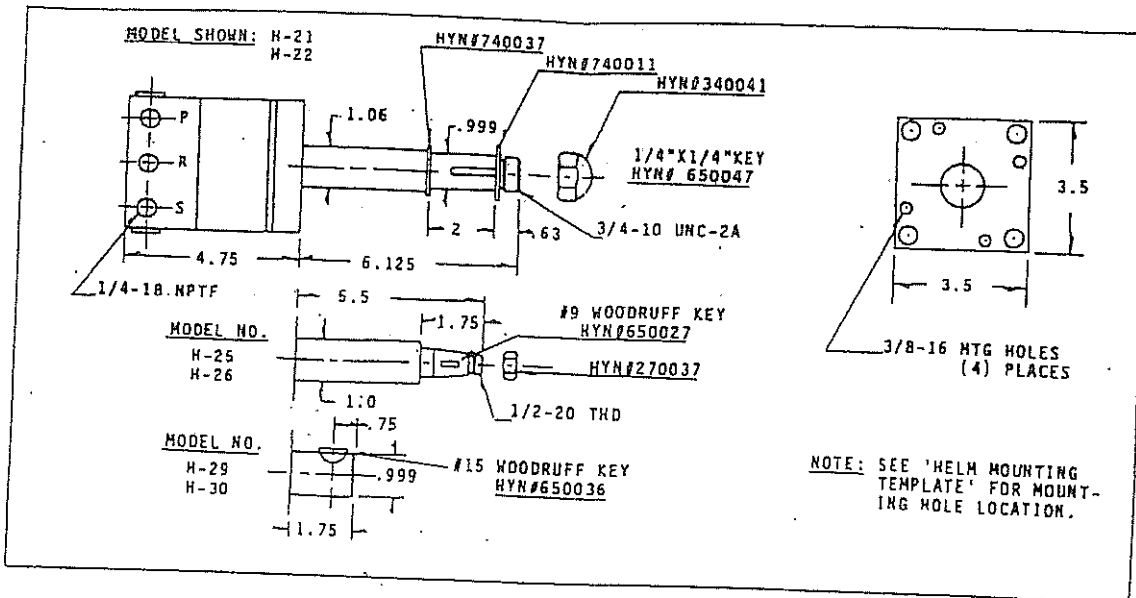

HELM UNIT SPECIFICATIONS

'S' Port Clockwise Rotation Discharge
'P' Port Counter Clockwise Rotation Discharge
'R' Port Reservoir

Service Pressure: 1000 psi.
Maximum Shaft Speed: 75 rpm.
Fluid: Clean-Petroleum Oil, 50 to 200 S.U.S. @ 100 F

HELM UNIT NO.	H-21	H-22	H-25	H-26	H-29	H-30	H-41	H-41-02	H-42	H-42-02	H-45
SHAFT STYLE											
1" Straight	X	X					X	X	X	X	
Teleflex Taper (1"/ft.)		X	X					X	X	X	
Auto Pilot					X	X					
HELM DISPLACEMENT											
2.00 cu-in/rev.	X	X	X	X	X						
2.75 cu-in/rev.											
4.00 cu-in/rev.	X	X	X	X	X						
5.50 cu-in/rev.									X	X	
								X	X		X